

City of Chico

Fire Prevention & Life Safety Bureau

Standard for Illuminated Directory

This standard has been developed for the purpose of clearly identifying and marking proper addresses, pursuant to Section 901.4.4 of the California Fire Code and Section 502 of the California Building Code, as adopted by the Chico City Council.

1. In addition to individual building suite or apartment numeral or letters, condominiums, apartment complexes, townhouses, mobile home parks and multiple commercial building developments shall have installed at points of entry, an Illuminated Directory Sign.
2. The directory sign shall be illuminated internally and shall consist of the following:
 - A. Each directory sign shall be “site oriented” to correctly represent the development as seen by the individual when viewing the sign.
 - B. A plot plan showing the building locations, private drives and access roads.
 - C. All numerals and street name designations shall be indicated in *Arial* font and **Bold** as follows:
 - Site address or address range for all buildings (minimum height of numbers shall be 1 ½”).
 - Building Number designations or Individually Addressed Buildings (minimum height of numbers shall be 1”).
 - Suite/Apartment unit number range (minimum height of numbers shall be ¾”).
 - Name of Complex/Development (maximum height of letters shall not be greater than the size of the Site address).
 - D. Indicate fire hydrant locations with a solid **RED** ½” circle.
 - E. A north direction indicator.
 - F. A reference point, i.e. “You are Here”, on the plot plan showing the location of the directory sign shall be indicated with a solid **GREEN** ¾” triangle.
 - G. Any text or numerals other than those specified under Section 2 Part C shall be a minimum of ¾” in height.
3. The developer or the property owner shall submit to the Building Division for review and approval a detailed plan showing size, materials, method of construction, electrical components and wiring, and the location(s) of the installation(s).
4. Figure 1 indicates the minimum dimensions of the directory (large complexes may require greater dimensions). For additional information contact the Fire Prevention Bureau at 530-897-3400 or the Building Division at 530 879-6700.

City of Chico
Fire Prevention and Life Safety Bureau

STANDARD
Illuminated Directory

Figure 1

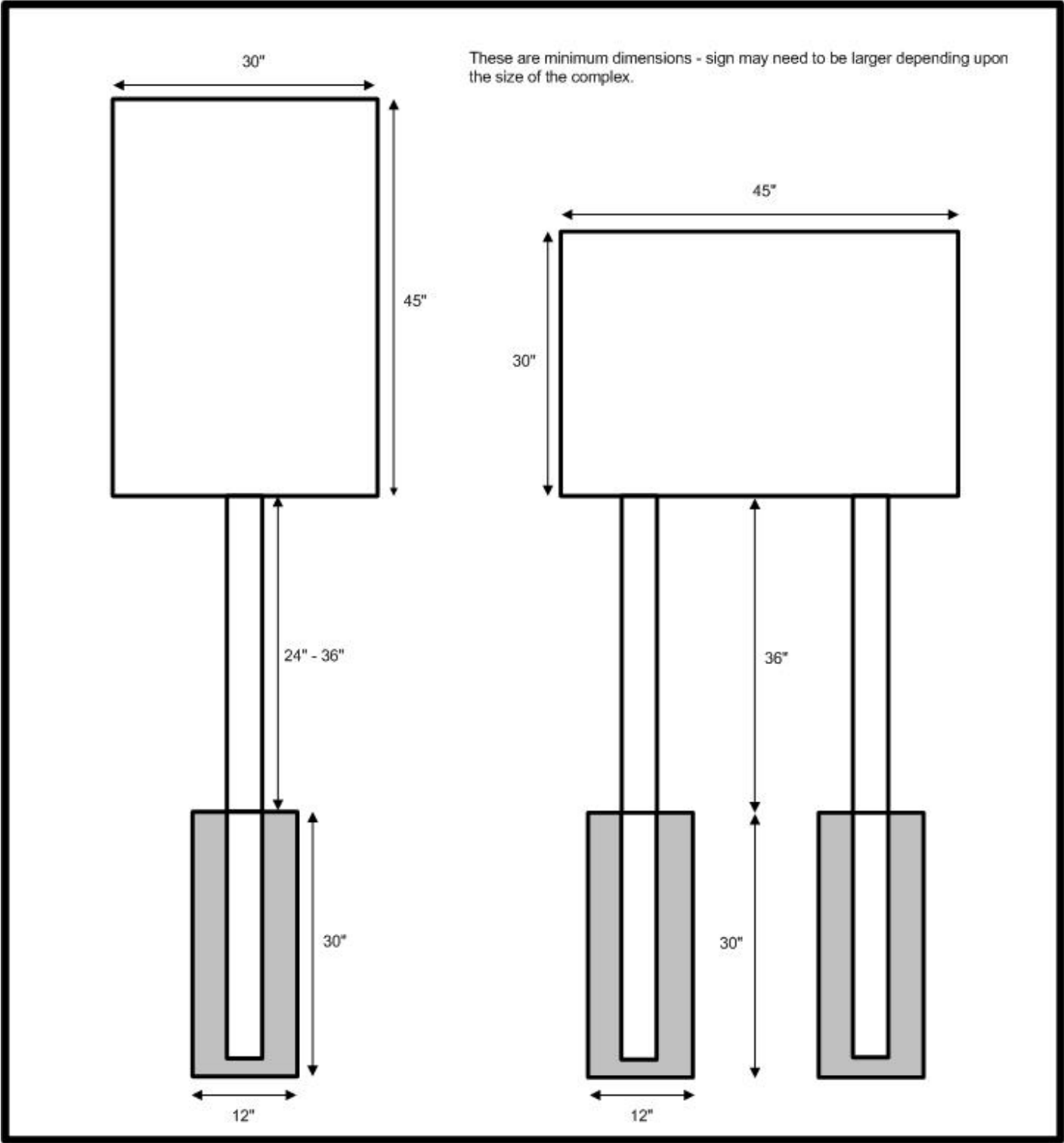

These are minimum dimensions - sign may need to be larger depending upon the size of the complex.